

Quick installation guide

ACS880-14 drive modules

(132 to 400 kW, 200 to 450 hp)

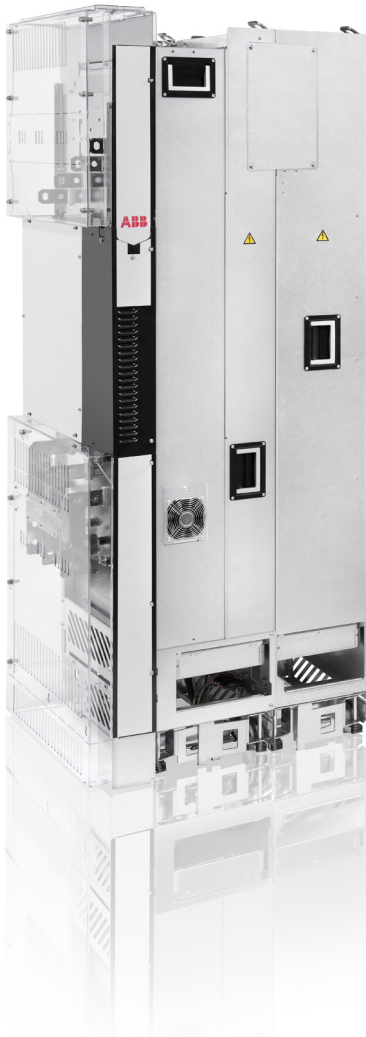

English 3

EN

List of related manuals

Drive hardware manuals and guides

Drive/converter/inverter safety instructions

Code (English)

Multilingual code:
[3AXD50000037978](#)

ACS880-14 drive modules (132 to 400 kW, 200 to 450 hp) hardware manual

[3AXD50000035160](#)

ACS880-14 drive modules (132 to 400 kW, 200 to 450 hp) quick installation guide

[3AXD50000212446](#)

ACX-AP-x Assistant control panels user's manual

[3AUA0000085685](#)

Drive firmware manuals and guides

ACS880 primary control program firmware manual

[3AUA0000085967](#)

Quick start-up guide for ACS880 drives with primary control program

[3AUA0000098062](#)

ACS880 IGBT supply control program firmware manual

[3AUA0000131562](#)

Option manuals and guides

DPMP-01 mounting platform for ACS-AP control panel installation guide

[3AUA0000100140](#)

DPMP-02/03 mounting platform for ACS-AP-X control panels installation guide

[3AUA0000136205](#)

FSO-12 safety functions module user's manual

[3AXD50000015612](#)

ACS880 ATEX-certified Safe disconnection function application guide

[3AUA0000132231](#)

FOCH du/dt filters hardware manual

[3AFE68577519](#)

Sine filters hardware manual

[3AXD50000016814](#)

Manuals and quick guides for I/O extension modules, fieldbus adapters, etc.

You can find manuals and other product documents in PDF format on the Internet. See section [Document library on the Internet](#) on the inside of the back cover. For manuals not available in the Document library, contact your local ABB representative.

The code below opens an online listing of the manuals applicable to this product.



[ACS880-14 manuals](#)

3AXD50000212446 Rev A

MUL

EFFECTIVE: 2018-03-23

© 2018 ABB Oy. All Rights Reserved.

EN – Quick installation guide

Contents of this guide

This guide tells you briefly how to install the drive module into a 800 mm wide Rittal TS 8 cabinet. For installation examples in different cabinets and more detailed instructions, engineering guide lines, technical data and complete safety instructions, see the hardware manual (www.abb.com/drives: Select *Document Library* and search for document number 3AXD50000035160 [English]).

EN

Obey the safety instructions

See figures on page 9. If you ignore these instructions, injury or death, or damage to the equipment can occur.



WARNING! Handle the drive module carefully. Open the support legs by pressing each leg a little down and turning it aside (1, 2).

Do not tilt the drive module. It is **heavy** and its **center of gravity is high**. The module will overturn from a sideways tilt of 5 degrees. Do not leave the module unattended on a sloping floor.

To prevent the drive module from falling, attach its top lifting lugs with chains to the cabinet frame before you push the module into the cabinet. Work carefully preferably with help from another person. Keep a constant pressure with one foot on the base of the module to prevent the module from falling on its back.



WARNING! If you are not a qualified electrical professional, do not do installation or maintenance work. Go through these steps before you begin any installation or maintenance work.

1. Clearly identify the work location.
 2. Disconnect all possible voltage sources.
 - Open the main disconnecter of the drive.
 - Open the disconnecter of the supply transformer as the main disconnecter of the drive does not remove the voltage from the input busbars of the drive.
 - Make sure that reconnection is not possible. Lock the disconnectors to open position and attach a warning notice to them.
 - Disconnect any external power sources from the control circuits before you do work on the control cables.
 - After you disconnect the drive, always wait for 5 minutes to let the intermediate circuit capacitors discharge before you continue.
 3. Protect any other energized parts in the work location against contact.
 4. Take special precautions when close to bare conductors.
-

5. Measure that the installation is de-energized.
 - Use a multimeter with an impedance of at least 1 Mohm.
 - Make sure that the voltage between the drive module input power terminals (L1/U1, L2/V1, L3/W1) and the grounding (PE) busbar is close to 0 V.
 - Make sure that the voltage between the drive module UDC+ and UDC- terminals and the grounding (PE) terminal is close to 0 V.
 6. Install temporary grounding as required by the local regulations.
 7. Ask for a permit to work from the person in control of the electrical installation work.
-

Select the power cables

Size the power cables according to local regulations to carry the nominal current given on the type designation label of your drive.

Ensure the cooling

See table on page 9 for the losses and the cooling air flow through the drive. The allowed operating temperature range of the drive without derating is -15 to +40 °C.

Protect the drive and input power cables

See table on page 9.

Installing the drive module and LCL filter module into a cabinet

See appendix [Step-by-step drawings for an installation example of standard drive configuration in Rittal TS 8 800 mm wide cabinet](#).

- Attach the plinth to the floor.
 - Attach the cabinet frame to the plinth.
 - Make the bottom plate with 360-degree grounding entries for power cables.
 - Attach the bottom plate to the cabinet.
 - Attach the punched section to the back of the cabinet frame.
 - Attach the mounting brackets to the punched section.
 - Install the pedestal to the LCL filter module.
 - Install the cooling fan to the LCL filter module.
 - Attach the LCL filter module pedestal guide plate to the cabinet bottom plate.
 - Attach the telescopic insertion ramp to the pedestal guide plate.
 - To prevent the LCL filter module from falling, attach its lifting lugs with chains to the cabinet frame.
 - Push the LCL filter module carefully into the cabinet along the telescopic insertion ramp. Work preferably with help from another person as shown below. Keep a
-

constant pressure with one foot on the base of the module to prevent the module from falling on its back

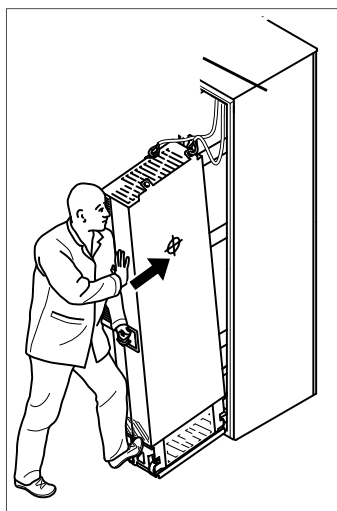



3AJA0000088632

- Unfasten the insertion ramp and attach the LCL filter module to bottom plate.
- Attach the drive module pedestal guide plate to the cabinet bottom plate.
- Attach the telescopic insertion ramp to the pedestal guide plate.
- Remove the sheeting from the clear plastic shrouds of the drive module from both sides.
- Install the top metallic shroud to the drive module.
- Install the back shrouds to the drive module.
- To prevent the drive module from falling, attach its lifting lugs with chains to the cabinet frame.
- Push the drive module carefully into the cabinet along the telescopic insertion ramp. Work preferably with help from another person. Keep a constant pressure with one foot on the base of the module to prevent the module from falling on its back.
- Unfasten the insertion ramp and attach the drive module to the bottom plate.
- Attach the LCL filter module and drive module to the punched section.
- Attach LCL filter module to the side of drive module from top and bottom. Reinstall the cover.
- Connect the LCL filter busbars to the drive module busbars with the connecting busbars.
- Connect the LCL filter fan power supply cable to connector FAN3:LCL.
- Connect the power cables and install the shrouds as described in section [Connecting the power cables and installing the shrouds](#).
- Install the external control unit and connect the control cables.
- Install the air baffles.

Connecting the power cables and installing the shrouds



Step	Task (motor cables)
1	Install the grounding terminal to the drive module base.
2	Run the motor cables to the cabinet. Ground the cable shields 360 degrees at the cabinet entry.
3	Connect the twisted shields of the motor cables to the grounding terminal.

EN

Step	Task (motor cables)
4	<p>Screw in and tighten the insulators to the drive module by hand. Install the T3/W2 connection terminal to the insulators.</p> <p> WARNING! Do not use longer screws or bigger tightening torque than given in the installation drawing. They can damage the insulator and cause dangerous voltage to be present at the module frame.</p> <p></p>
5	Connect the phase T3/W2 conductors to the T3/W2 terminal.
6	Install the T2/V2 connection terminal to the insulators See the warning in step 4.
7	Connect the phase T2/V2 conductors to the T2/V2 connection terminal.
8	Install the T1/U2 connection terminal to the insulators. See the warning in step 4.
9	Connect the phase T1/U2 conductors to the T1/U2 terminal.
10	Remove the plastic sheeting from the output clear plastic shrouds from both sides.
11	Install the shrouds to the drive module.
12	Install the lower front cover to the drive module.

Step	Task (input cables)
1	Ground the input cable shields (if present) 360 degrees at the cabinet entry.
2	Connect the twisted shields of the input cables and separate ground cable (if present) to the cabinet grounding busbar.
3	<p>Step drill carefully sufficiently big holes to the entry clear plastic shroud for the cables to be connected. Align the holes in the vertical direction according to the alignment holes in the shroud. Smooth the hole edges.</p> <p>Remove the plastic sheeting from both sides of the shroud.</p> <p>Attach the cables firmly to the cabinet frame to prevent chafing against the hole edges.</p>
4	Put the conductors of the input cables through the drilled holes in the clear plastic shroud.
5	<u>For drive modules without option +H370:</u> Connect the input cable conductors to the drive module L1/U1, L2/V1 and L3/W1 connection busbars, Go to step 12.

For option +H370: Do steps 6 to 11.

6	<p>Screw in and tighten the insulators to the drive module by hand. Install the L1/U1 connection terminal to the insulators.</p> <p> WARNING! Do not use longer screws or bigger tightening torque than given in the installation drawing. They can damage the insulator and cause dangerous voltage to be present at the module frame.</p> <p></p>
7	Connect the L1/U1 conductors to the L1/U1 connection terminal.
8	Install the L2/V1 connection terminal to the insulators. See the warning in step 5.
9	Connect the L2/V1 conductors to the L2/V1 connection terminal.
10	Install the L3/W1 connection terminal to the insulators. See the warning in step 5.
11	Connect the L3/W1 conductors to the L3/W1 connection terminal.
12	Install the entry clear plastic shroud. Install the front clear plastic shroud and upper front cover. Remove the cardboard protective covering from the drive module air outlet.
13	Install the side and top clear plastic shrouds to the drive module.

■ Default I/O connections

The default I/O connections of the Factory macro of the ACS880 primary control program are shown below.

Wire sizes and tightening torques of the control board terminals: 0.5 ... 2.5 mm² (24...14 AWG) and 0.5 N·m (4 lbf·in) for both stranded and solid wiring.

EN

Relay outputs		XRO1...XRO3	
Ready 250 V AC / 30 V DC 2 A	NO	13	
	COM	12	
	NC	11	
Running 250 V AC / 30 V DC 2 A	NO	23	
	COM	22	
	NC	21	
Faulted(-1) 250 V AC / 30 V DC 2 A	NO	33	
	COM	32	
	NC	31	
External power input		XPOW	
24 V DC, 2 A	GND	2	
	+24VI	1	
Reference voltage and analog inputs		J1, J2, XAI	
AI1/AI2 current/voltage selection	AI1: U	AI2: U	
	AI1: I	AI2: I	
By default not in use. 0(4)...20 mA, R _{in} = 100 ohm	AI2-	7	
	AI2+	6	
Speed reference 0(2)...10 V, R _{in} > 200 kohm	AI1-	5	
	AI1+	4	
Ground	AGND	3	
-10 V DC, R _L 1...10 kohm	-VREF	2	
10 V DC, R _L 1...10 kohm	+VREF	1	
Analog outputs		XAO	
Motor current 0...20 mA, R _L < 500 ohm	AGND	4	
	AO2	3	
Motor speed rpm 0...20 mA, R _L < 500 ohm	AGND	2	
	AO1	1	
Drive-to-drive link		J3, XD2D	
Drive-to-drive link termination	ON	OFF	
	Shield	4	
Drive-to-drive link	BGND	3	
	A	2	
	B	1	
Safe torque off		XSTO	
Safe torque off. Both circuits must be closed for the drive to start.	IN2	4	
	IN1	3	
	SGND	2	
	OUT	1	
Digital inputs		XDI	
By default not in use.	DI6	6	
Constant speed 1 select (1 = on)	DI5	5	
Acceleration & deceleration select	DI4	4	
Reset	DI3	3	
Forward (0) / Reverse (1)	DI2	2	
Stop (0) / Start (1)	DI1	1	
Digital input/outputs		XDIO	
Output: Running	DIO2	2	
Output: Ready	DIO1	1	
Ground selection		J6	
Auxiliary voltage output, digital input interlock		XD24	
Digital input/output ground	DIOGND	5	
+24 V DC 200 mA ¹⁾	+24VD	4	
Digital input ground	DICOM	3	
+24 V DC 200 mA ¹⁾	+24VD	2	
Run enable	DIIL	1	
Safety functions module connection		X12	
Control panel connection		X13	
Memory unit connection		X205	

¹⁾ Total load capacity of these outputs is 4.8 W (200 mA / 24 V) minus the power taken by DIO1 and DIO2.

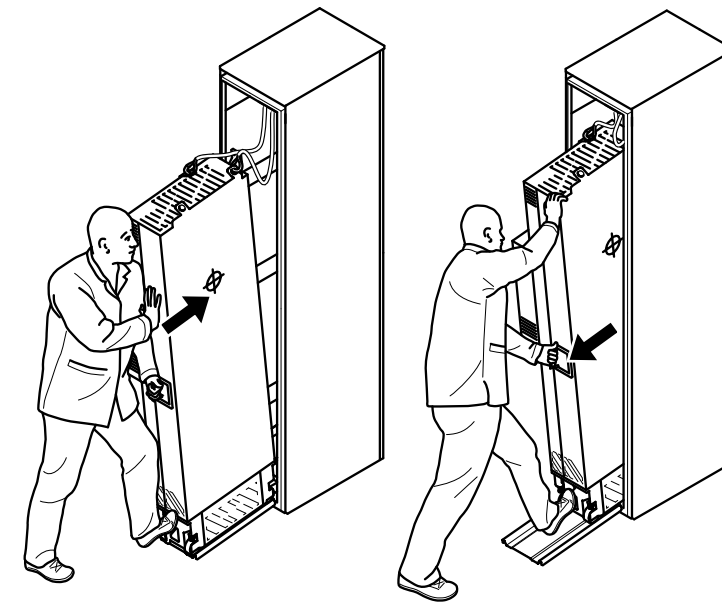
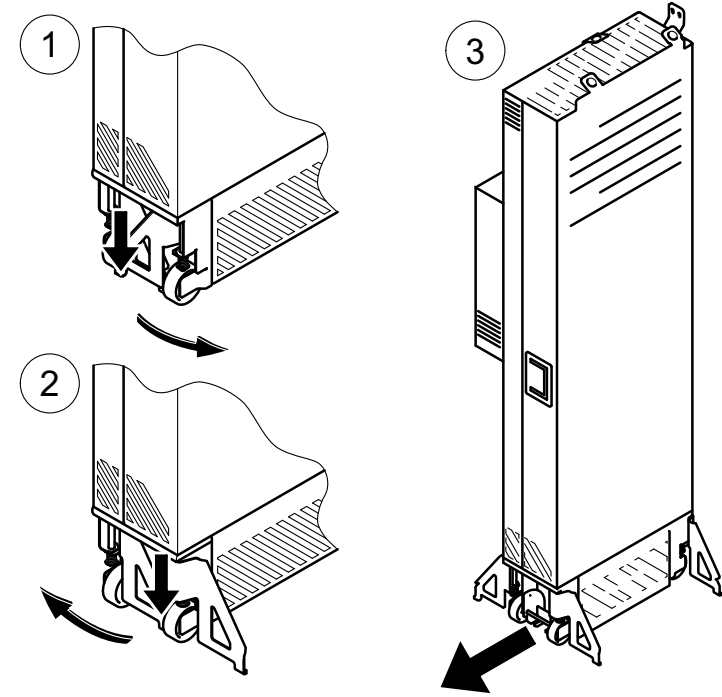
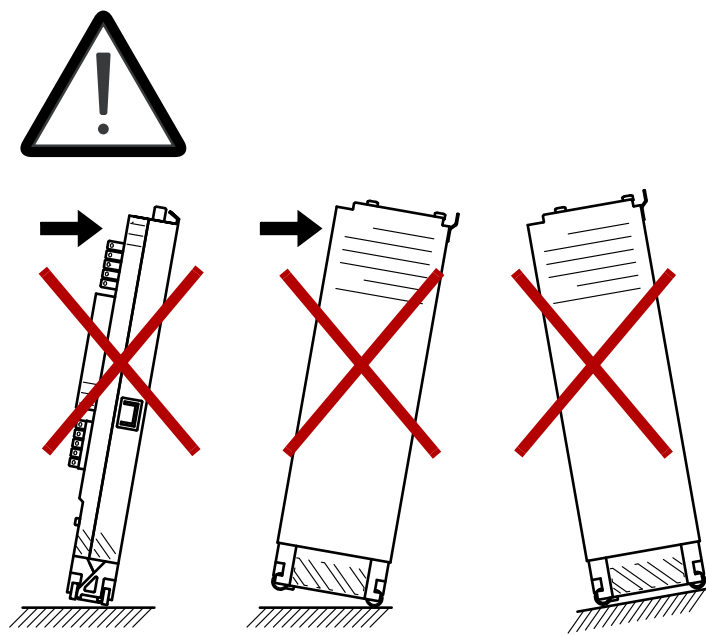

Drive type ACS880-14-	Air flow m ³ /h	Losses W	Type DIN 43653
U_N = 400 V			
246A-3	2100	5280	170M5408
293A-3	2100	6400	170M5410
363A-3	2100	8000	170M6410
442A-3	2100	10000	170M6411
505A-3	2100	10000	170M6412
585A-3	2100	12600	170M6414
650A-7	2100	14200	170M6414
U_N = 500 V			
240A-5	2100	5280	170M4410
260A-5	2100	6400	170M5408
302A-5	2100	8000	170M5410
361A-5	2100	8000	170M6410
414A-5	2100	10000	170M6411
460A-5	2100	12600	170M6411
503A-5	2100	14200	170M6412
U_N = 690 V			
142A-7	2100	5280	170M4409
174A-7	2100	6400	170M4410
210A-7	2100	8000	170M5408
271A-7	2100	10000	170M5410
330A-7	2100	12600	170M6410
370A-7	2100	14200	170M6411
430A-7	2100	16000	170M6411

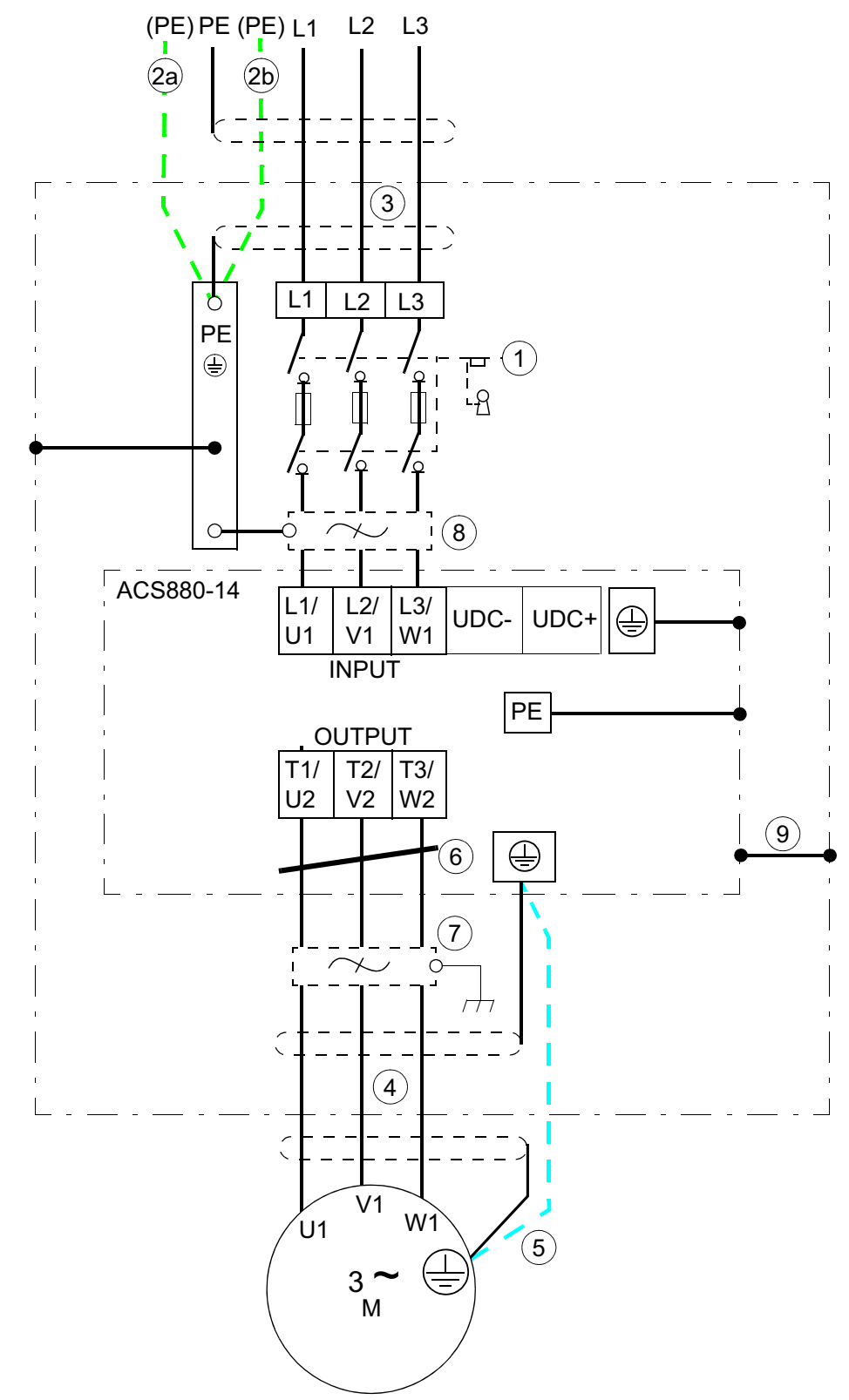
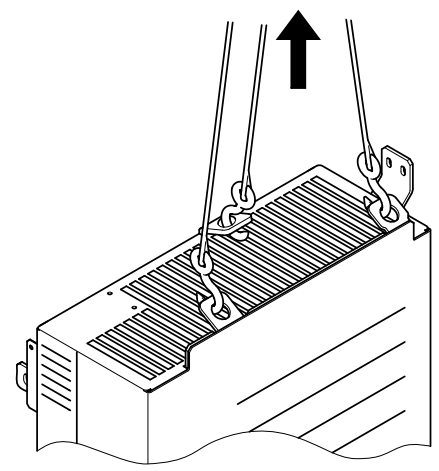

WARNING! The UDC+ and UDC- terminals of the drive module must not be used for any other than optional external brake chopper connection.

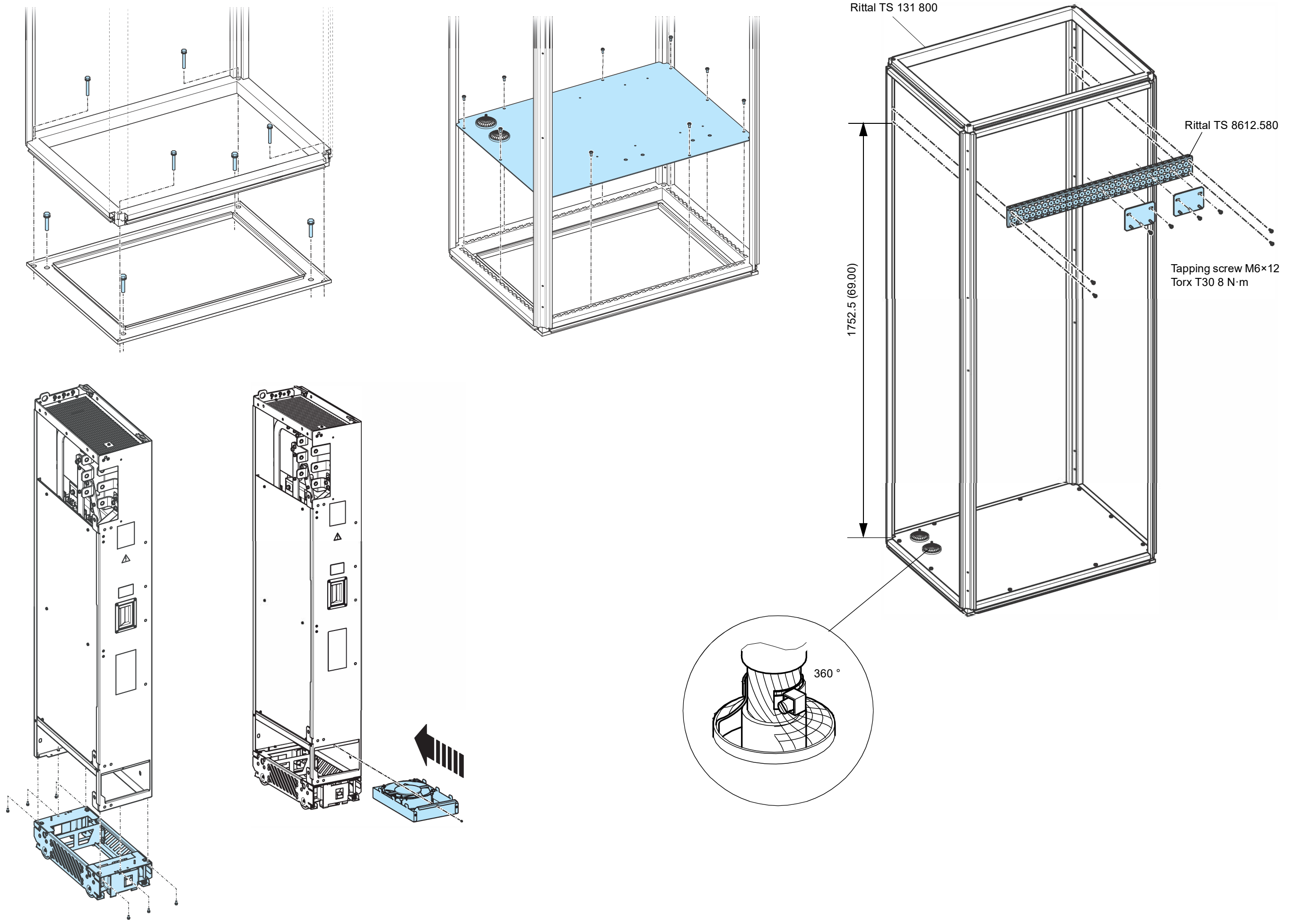

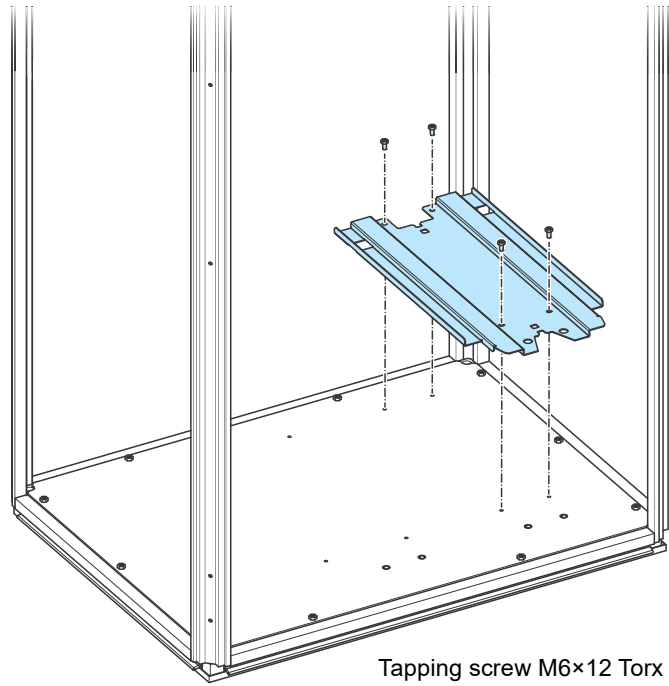

Tapping screw M6×12 Torx T30
(Hex) 8 N·m

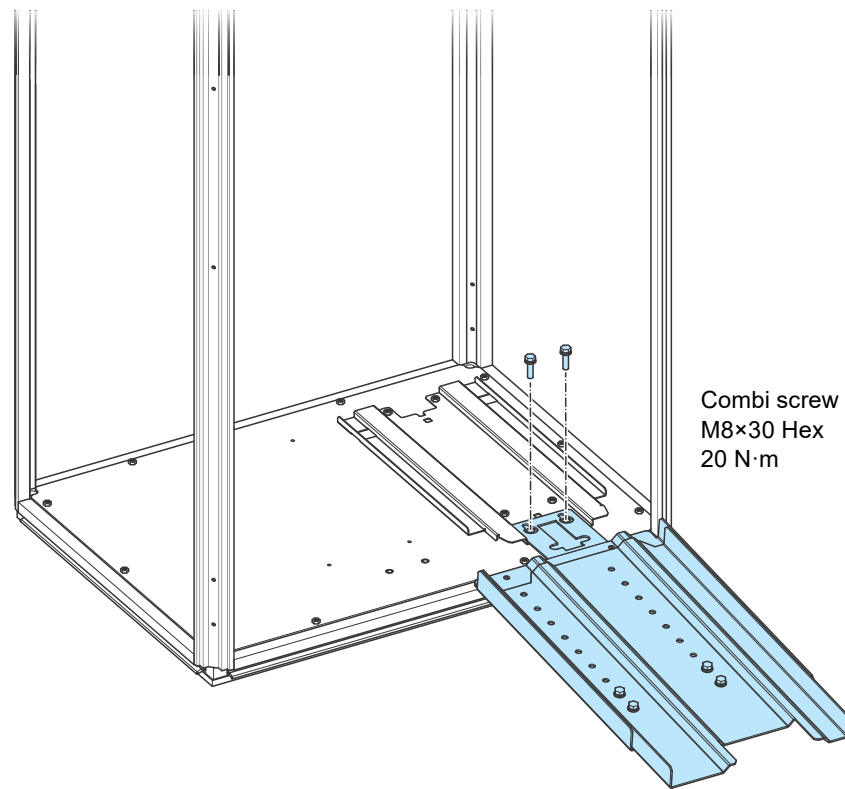

Combi screw
M8×30 Hex
20 N·m

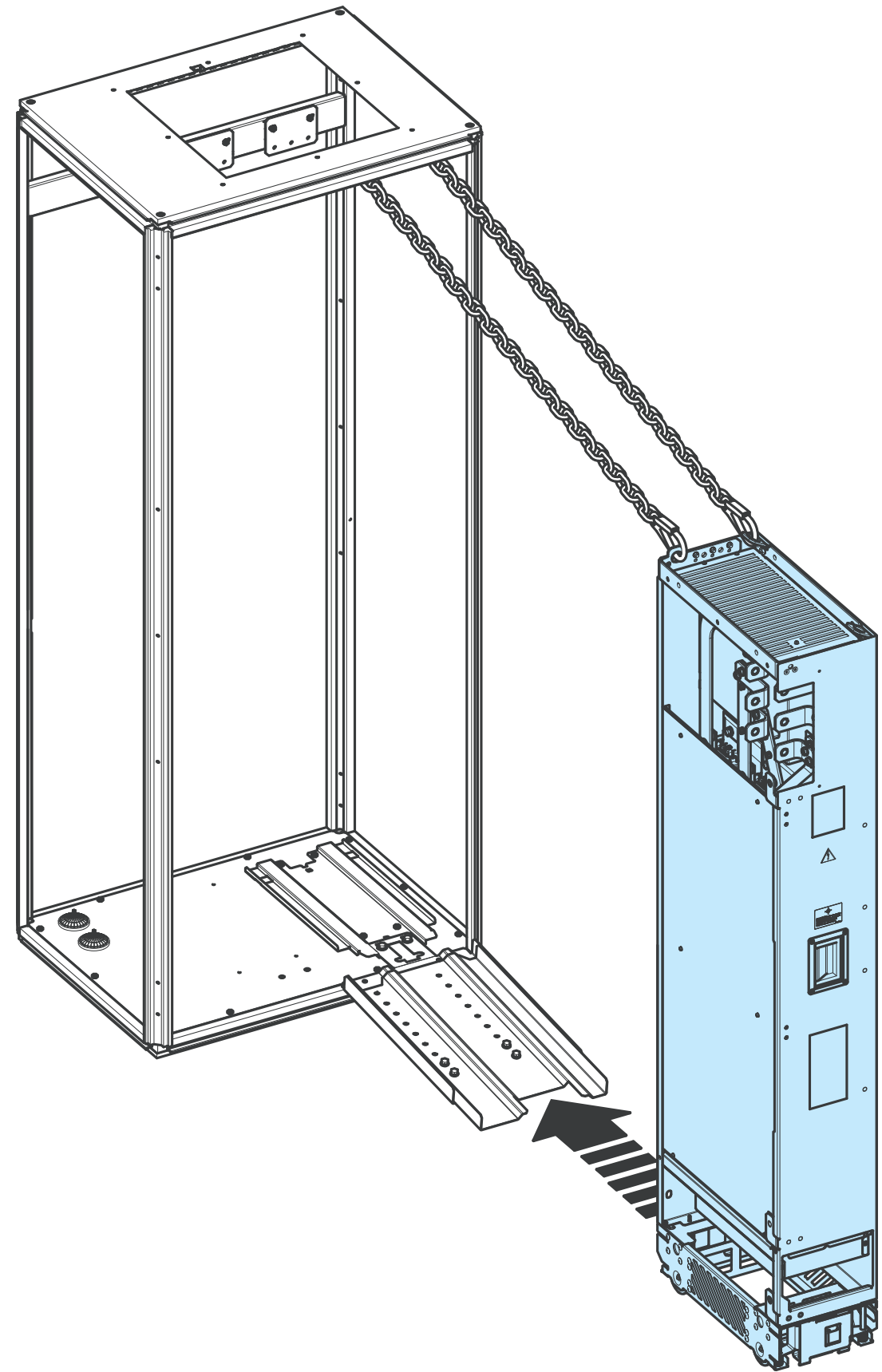

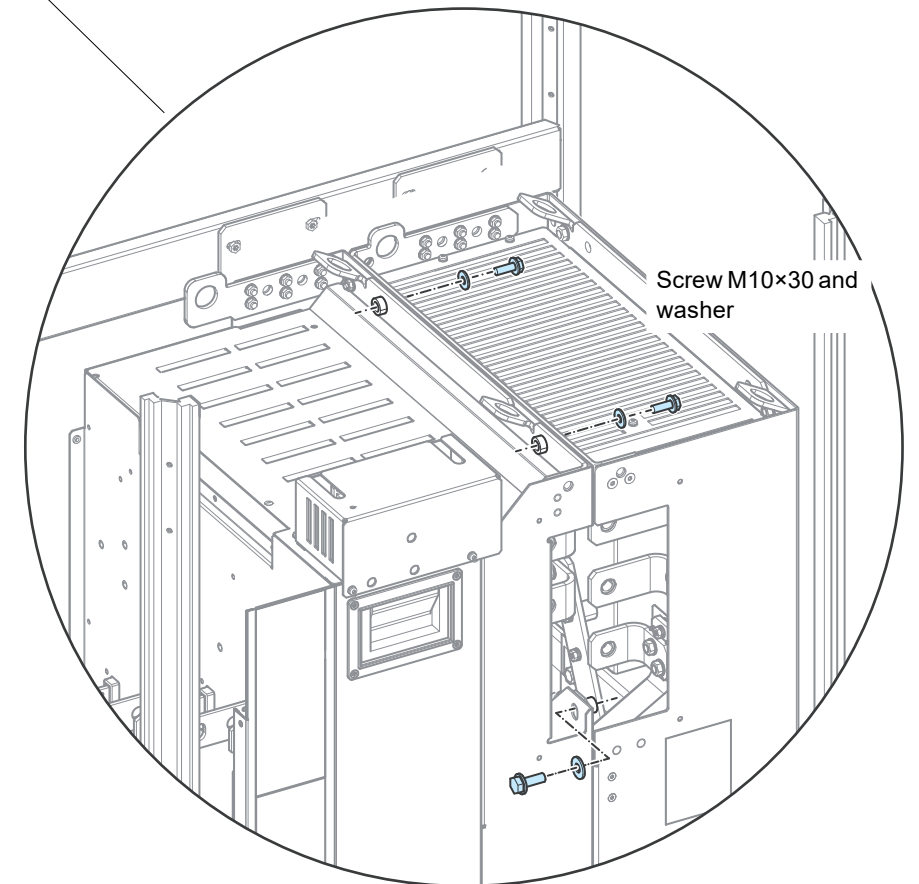
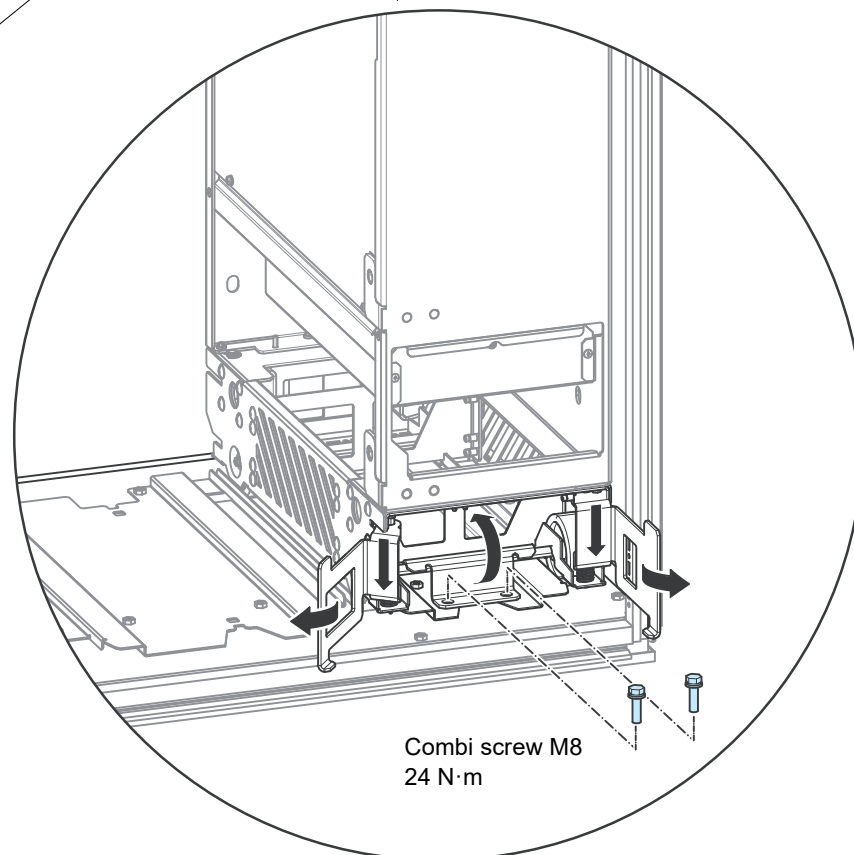
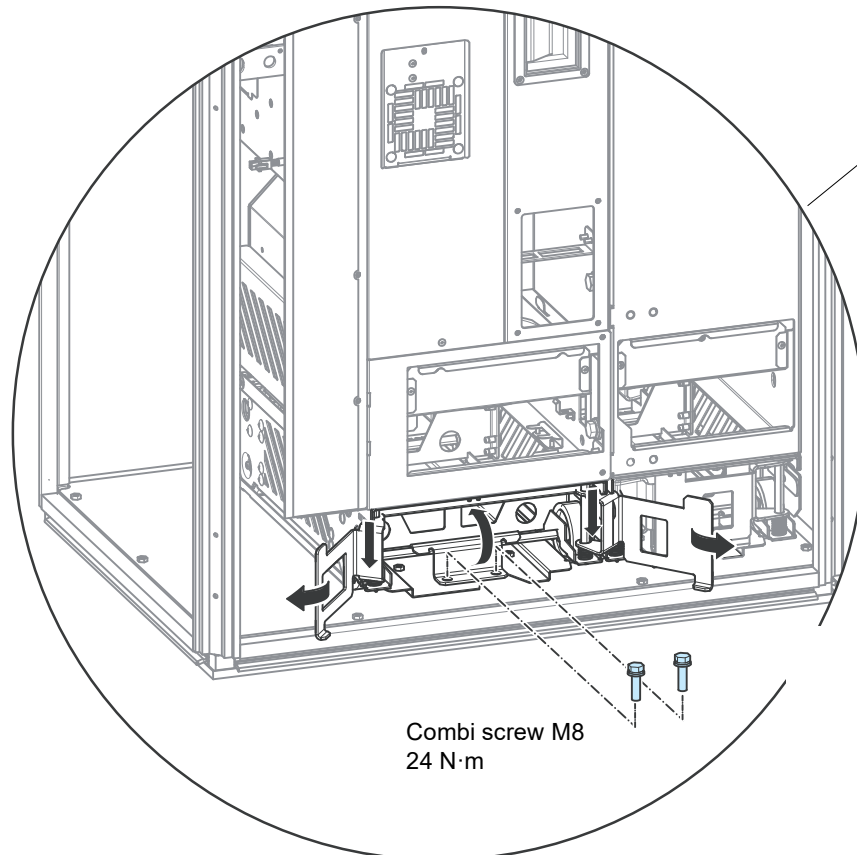
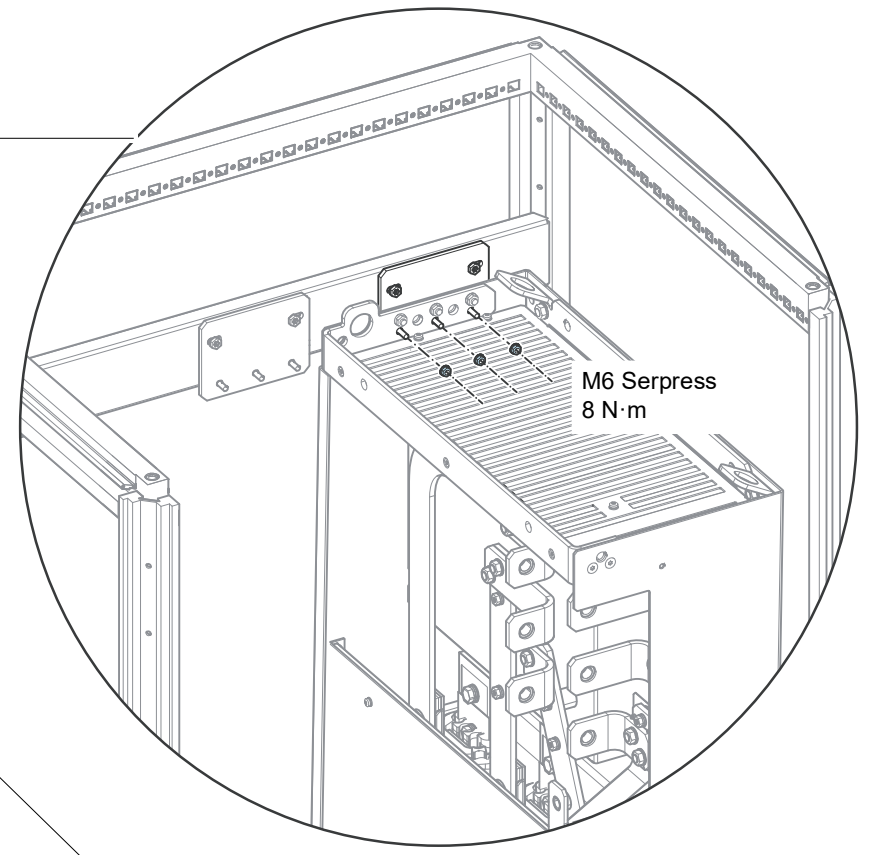
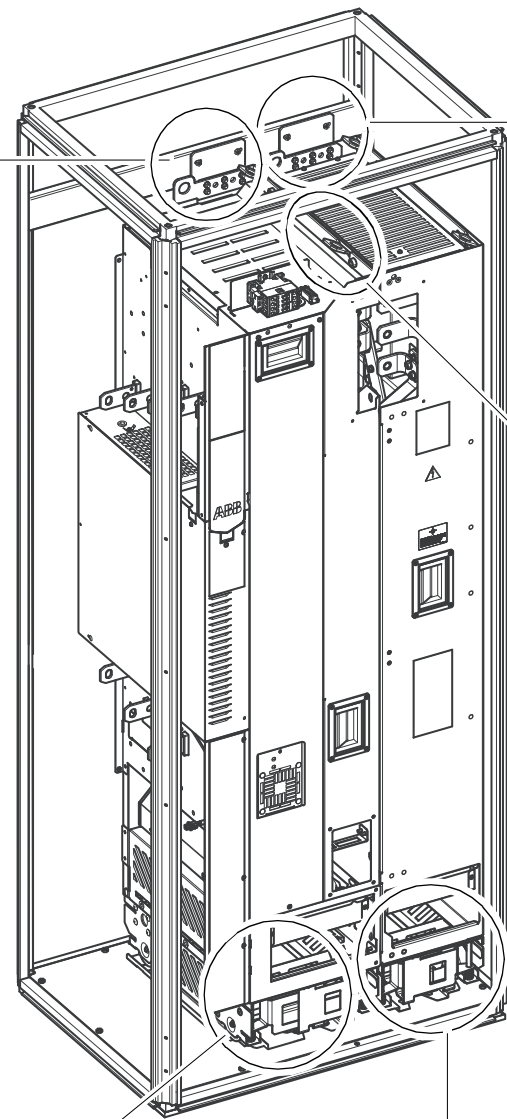
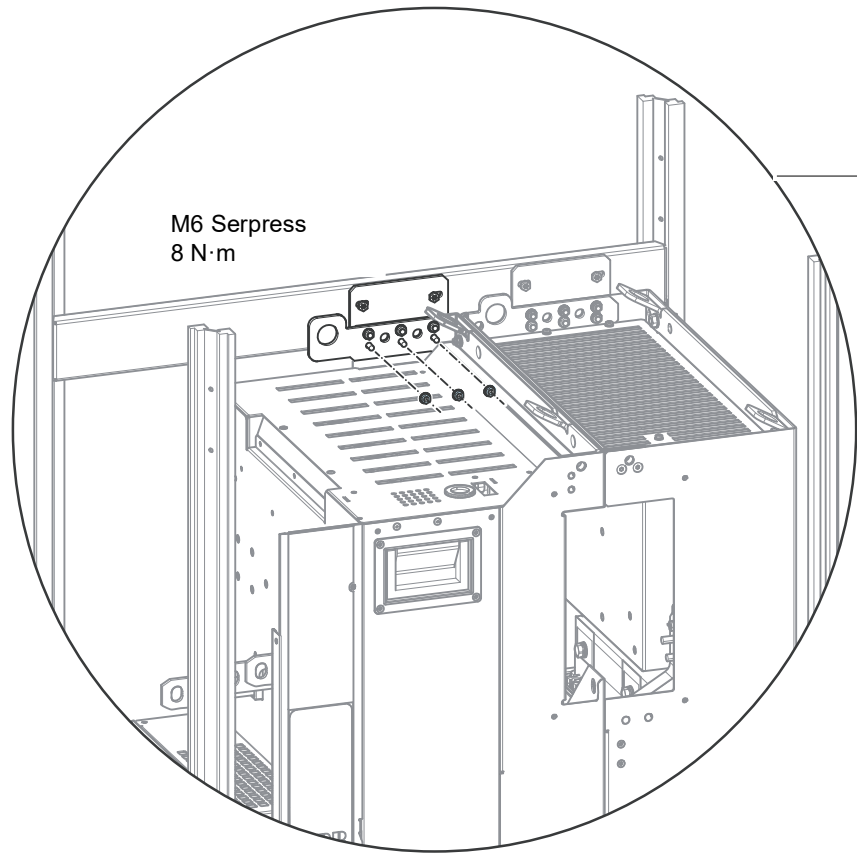

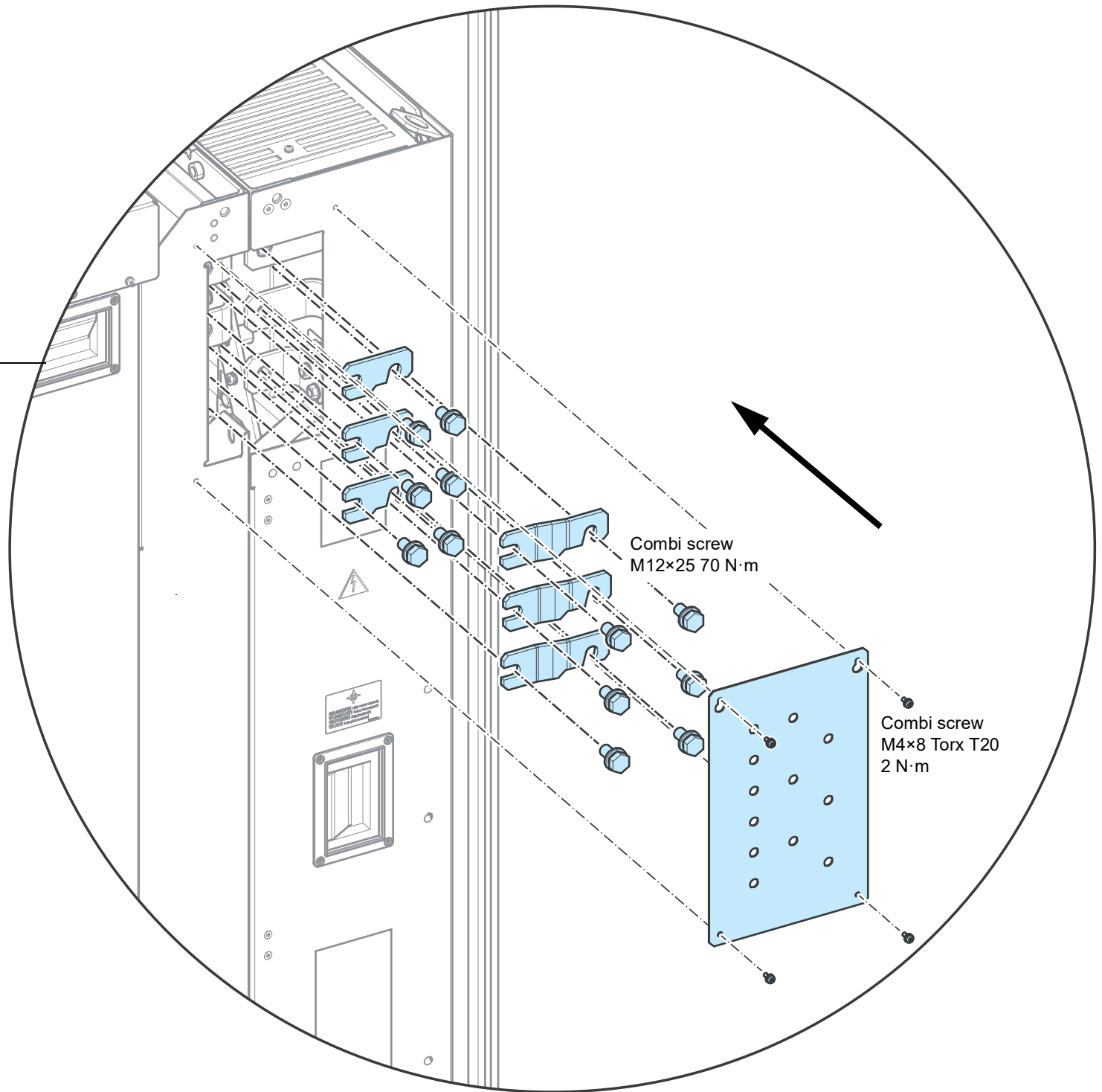
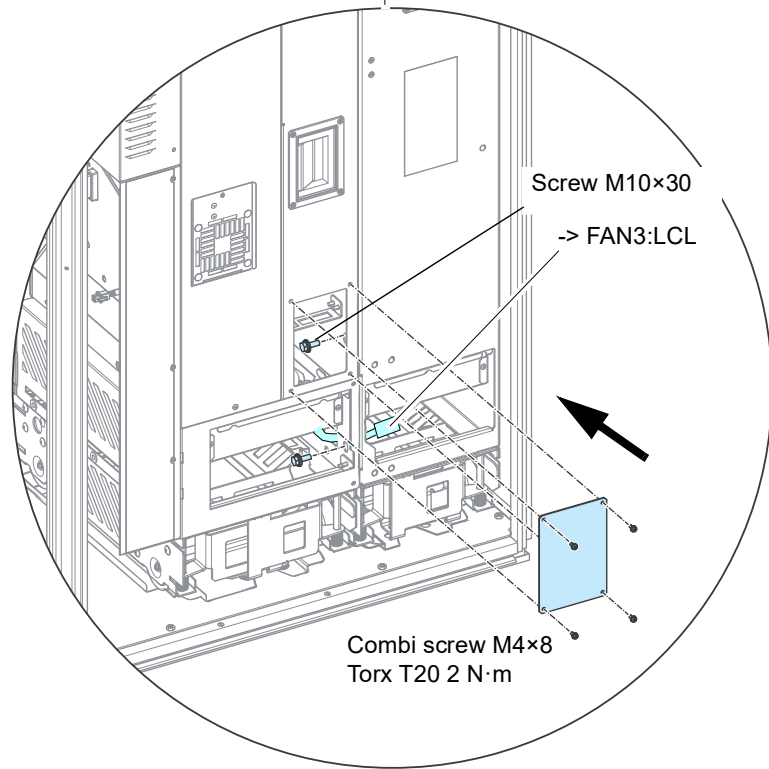
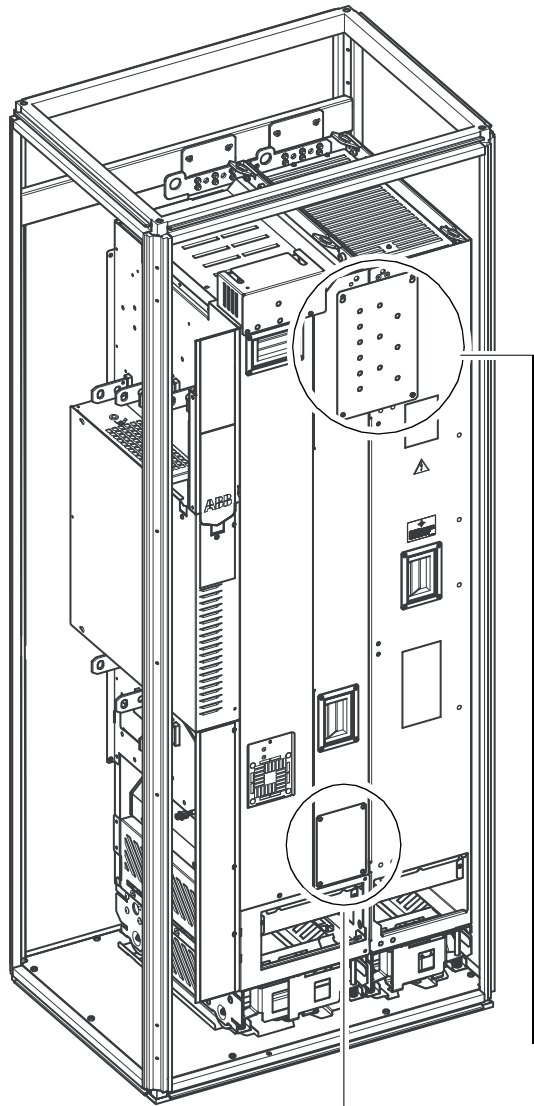

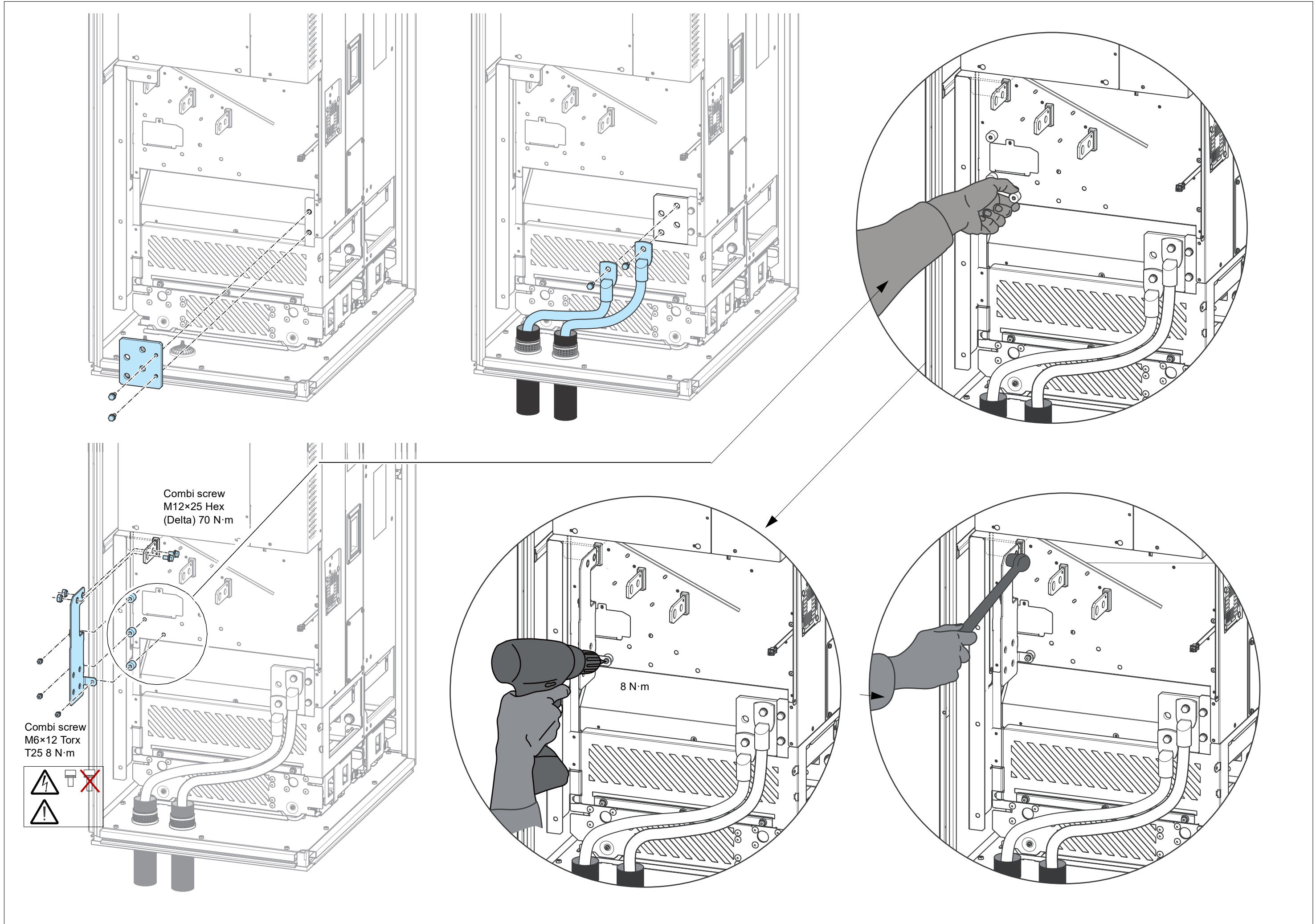

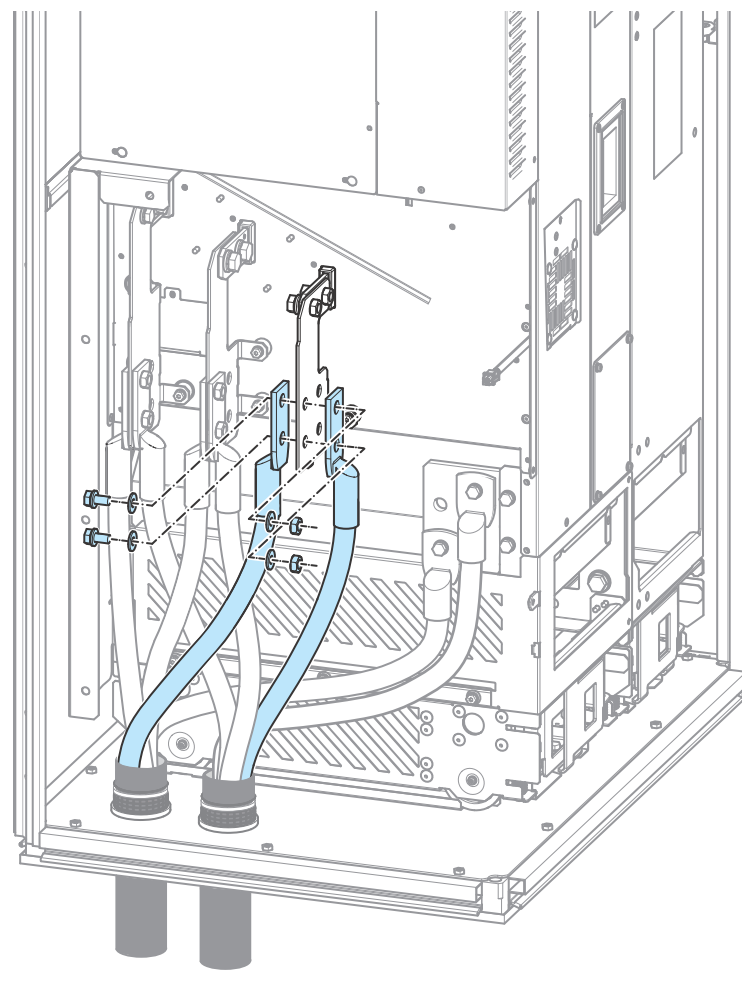
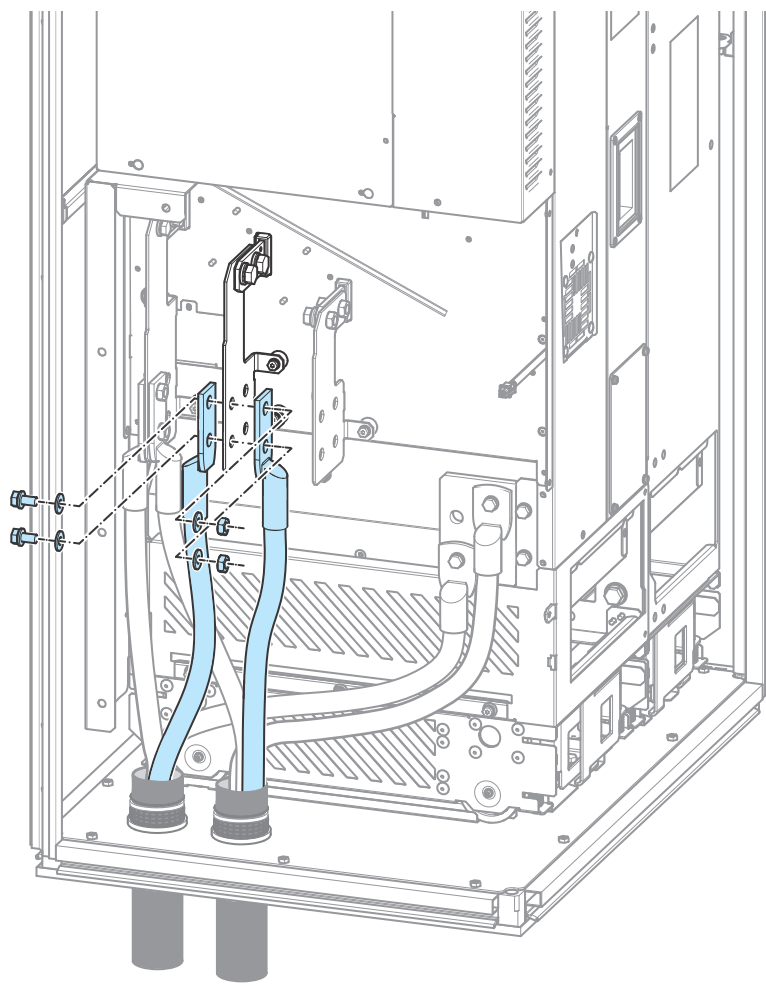
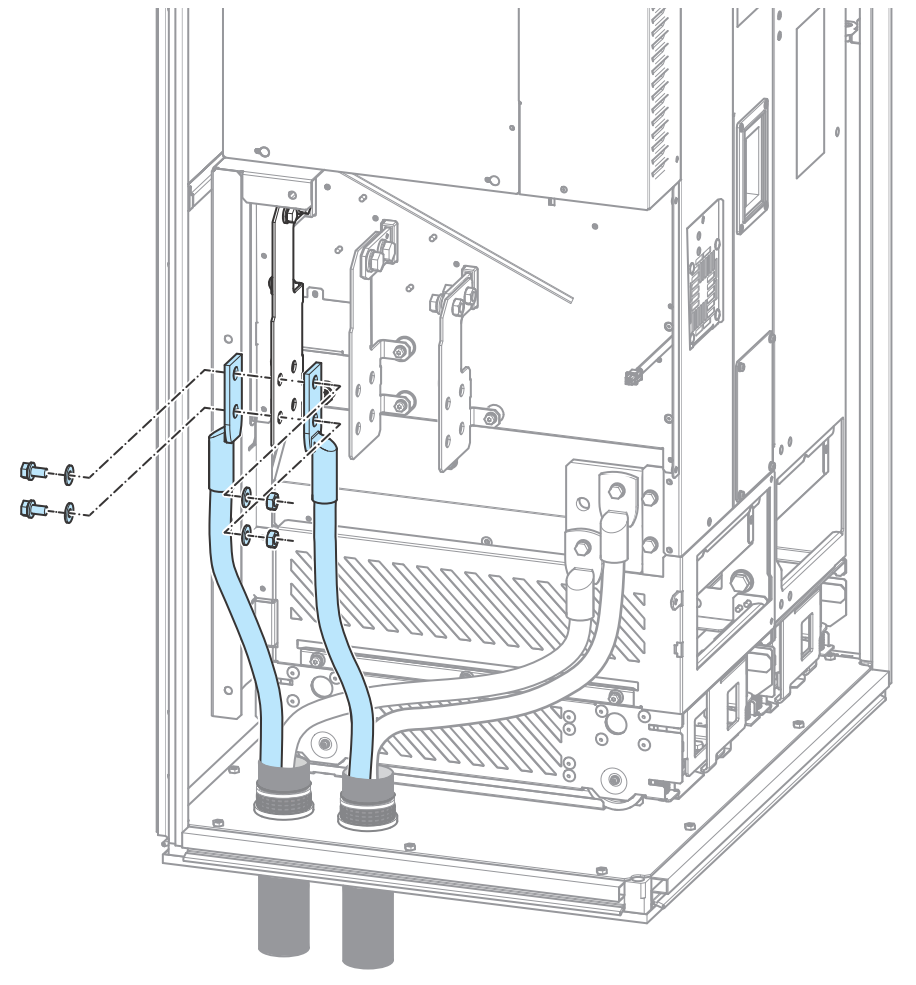
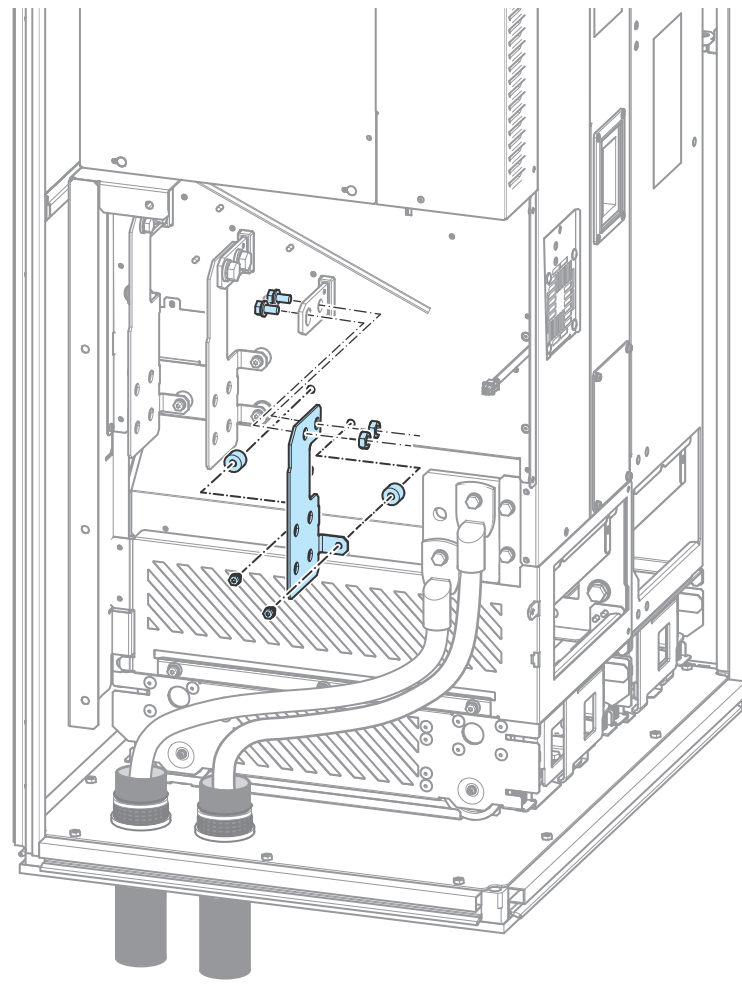
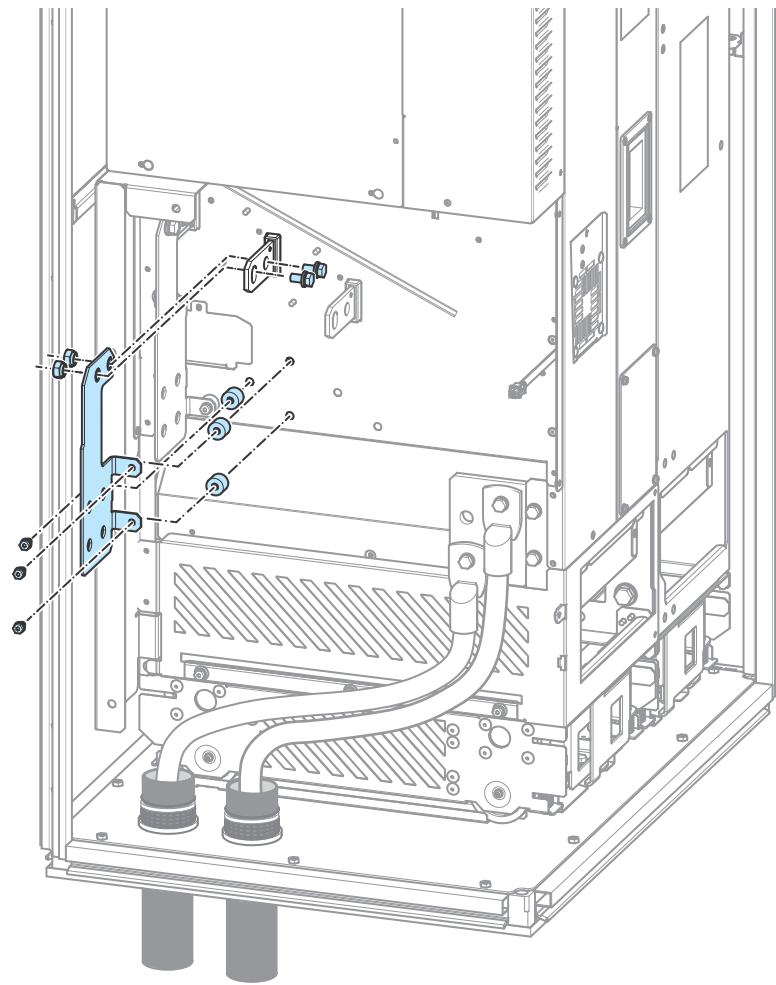

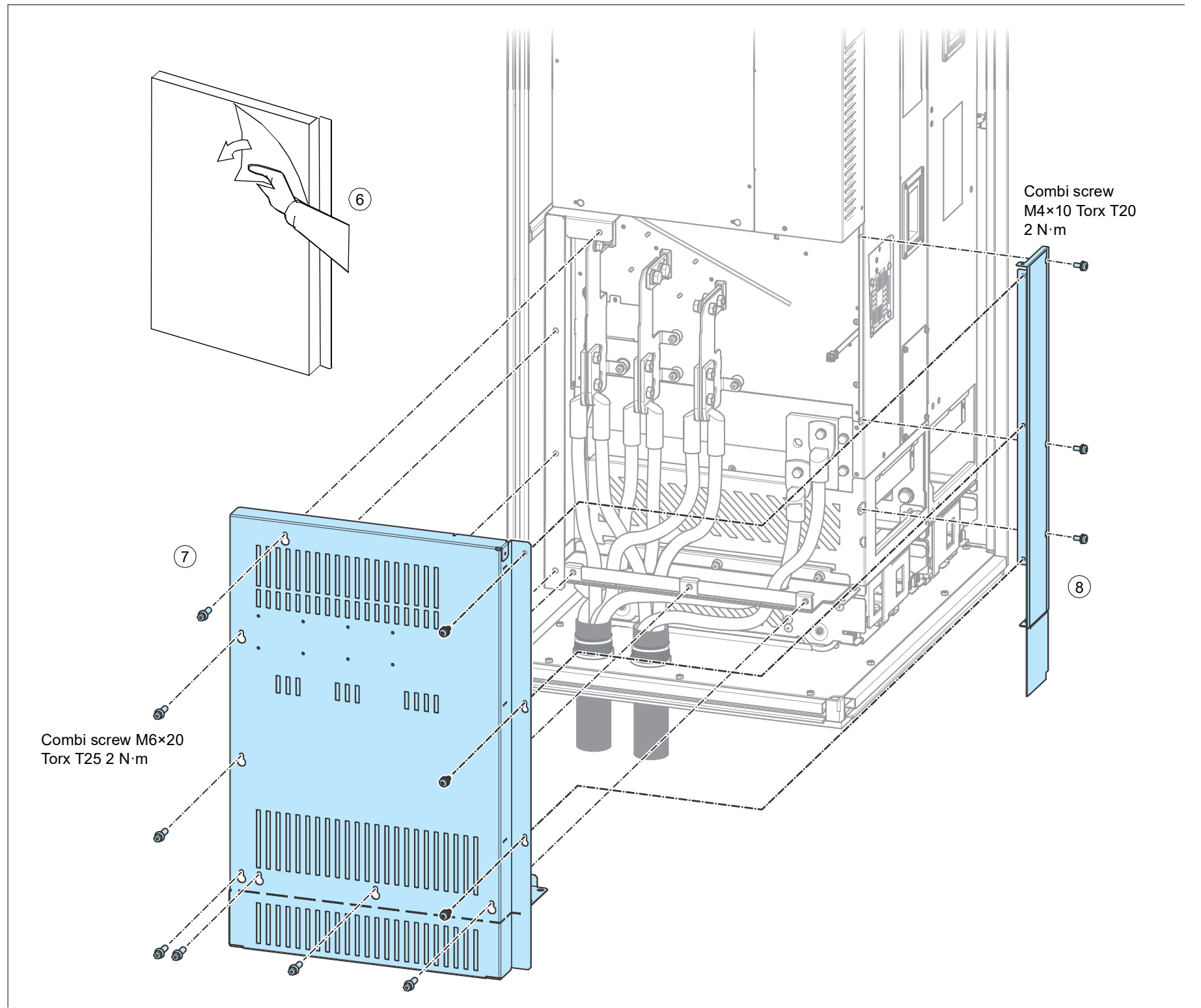
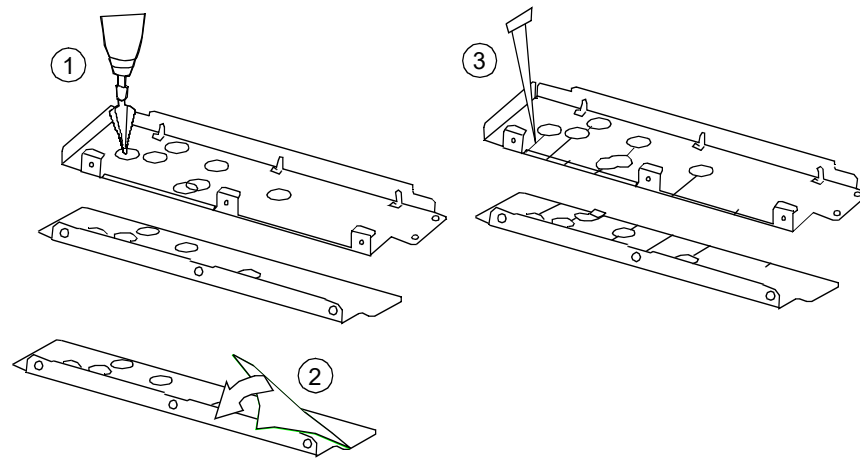
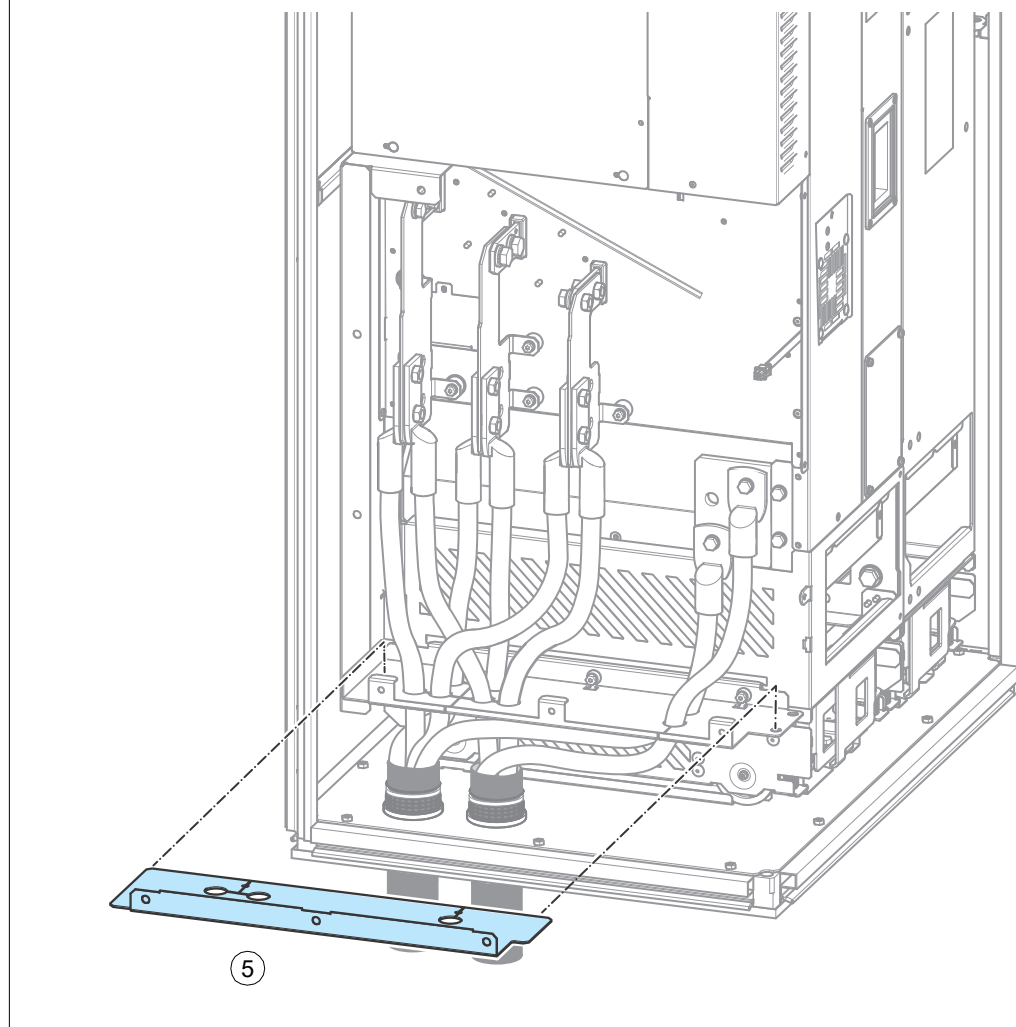
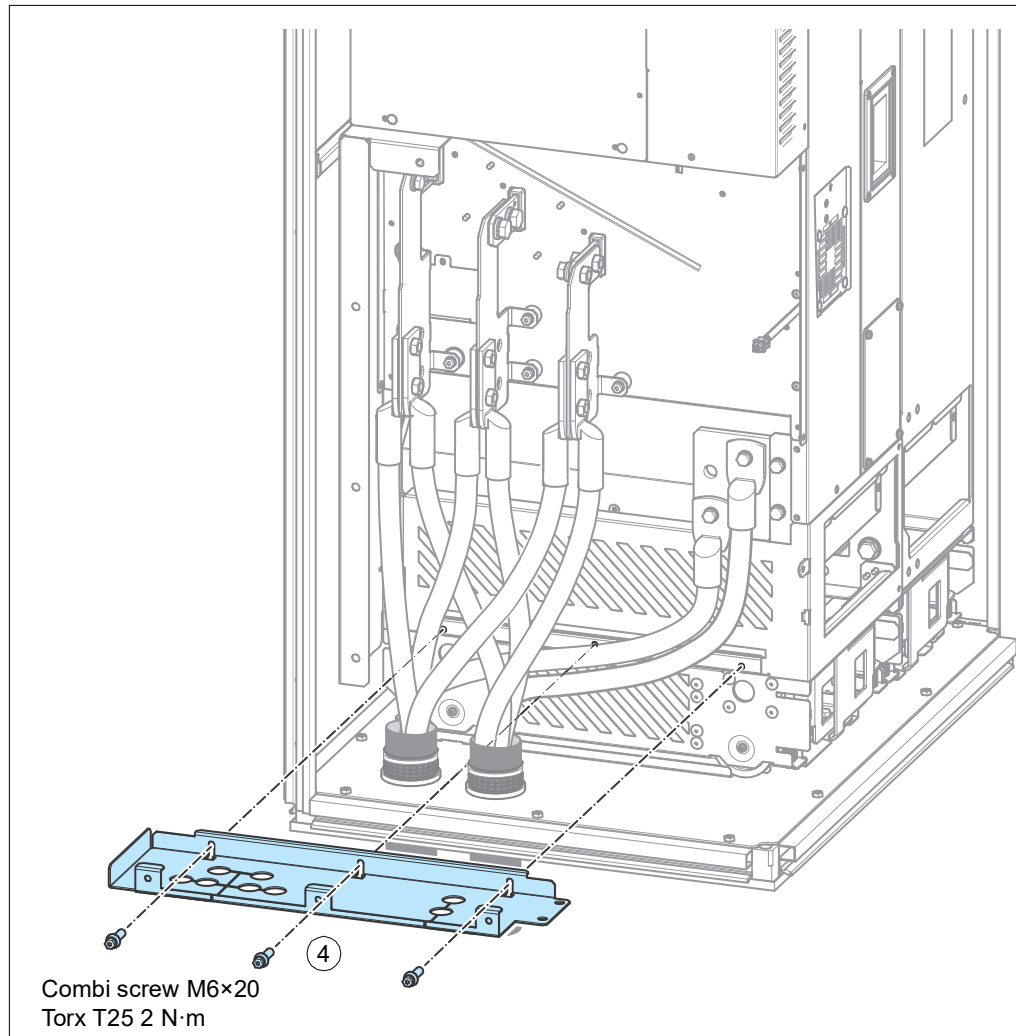

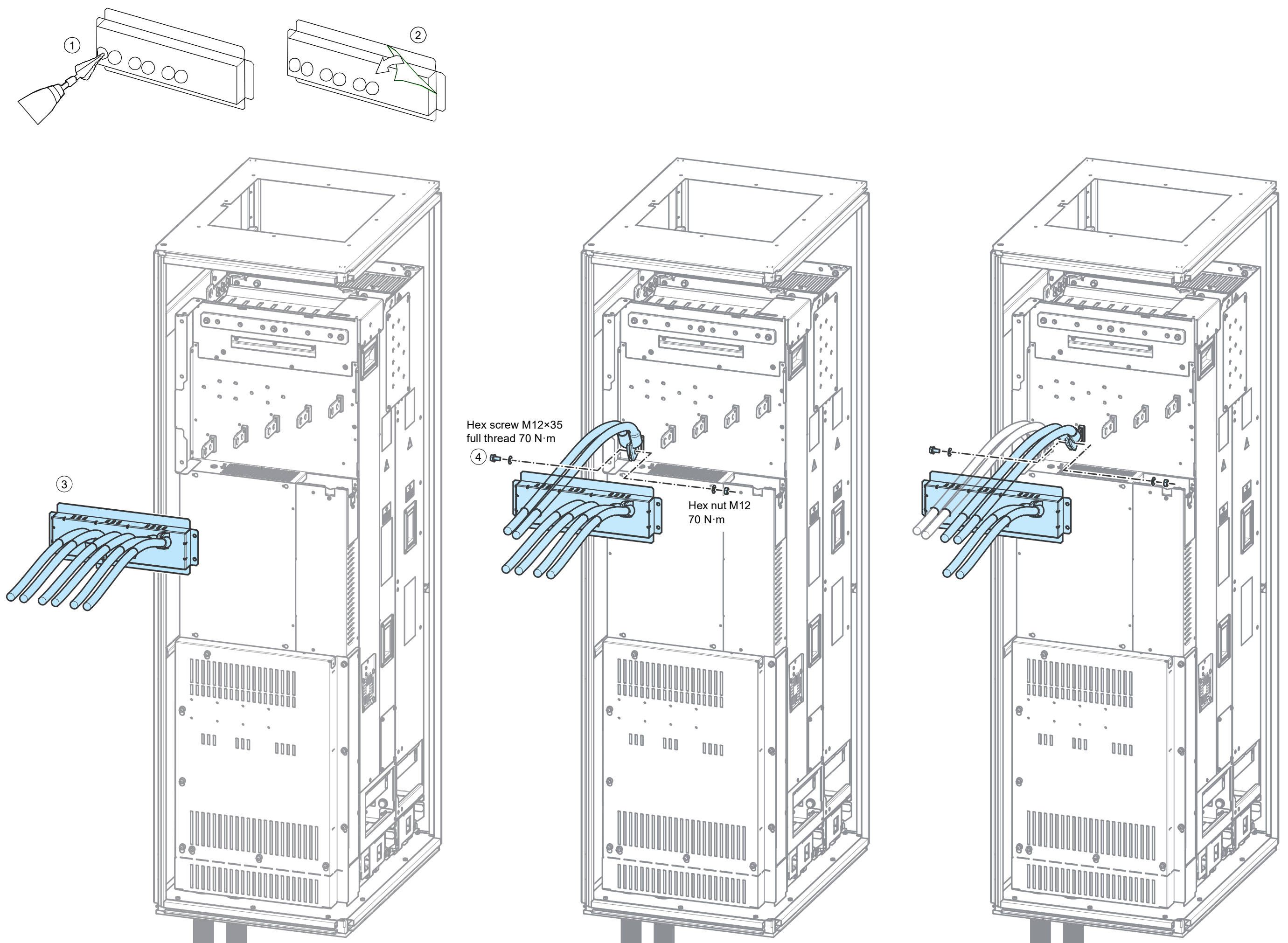

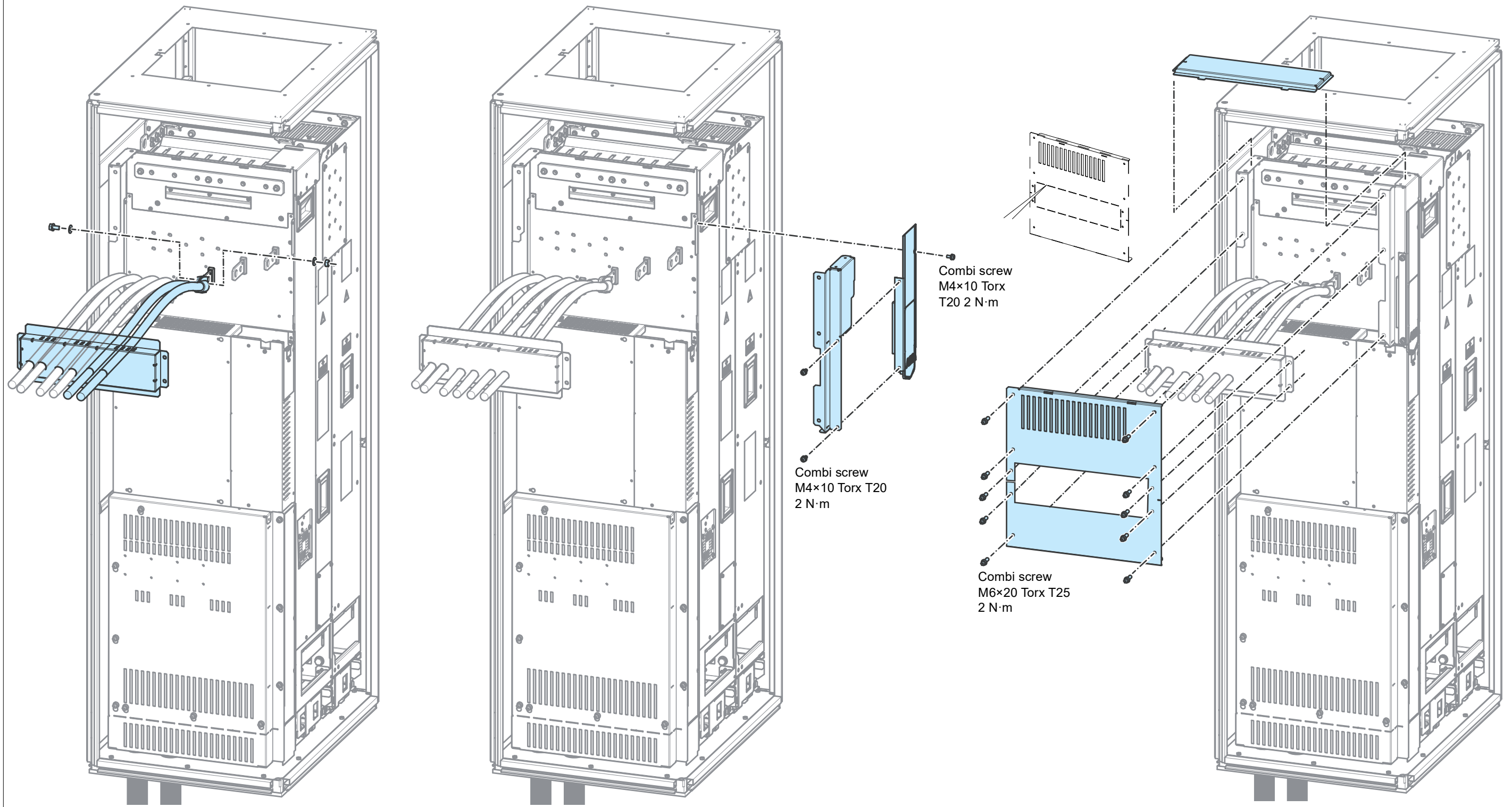

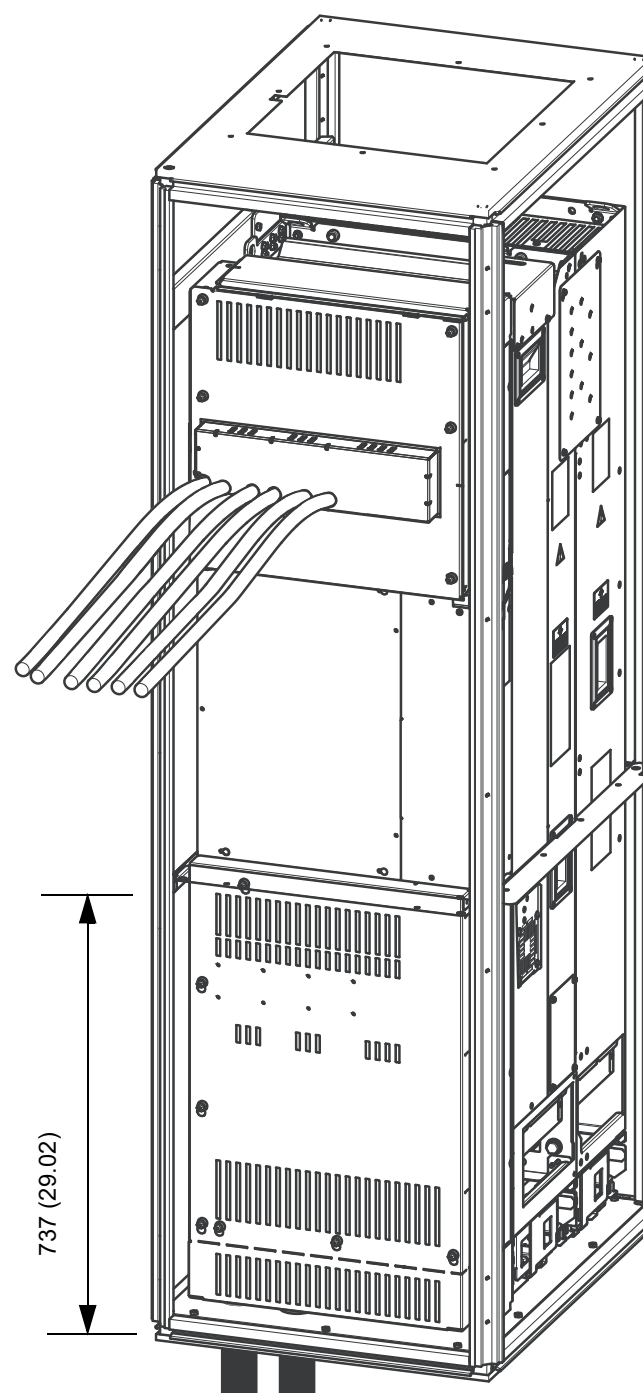
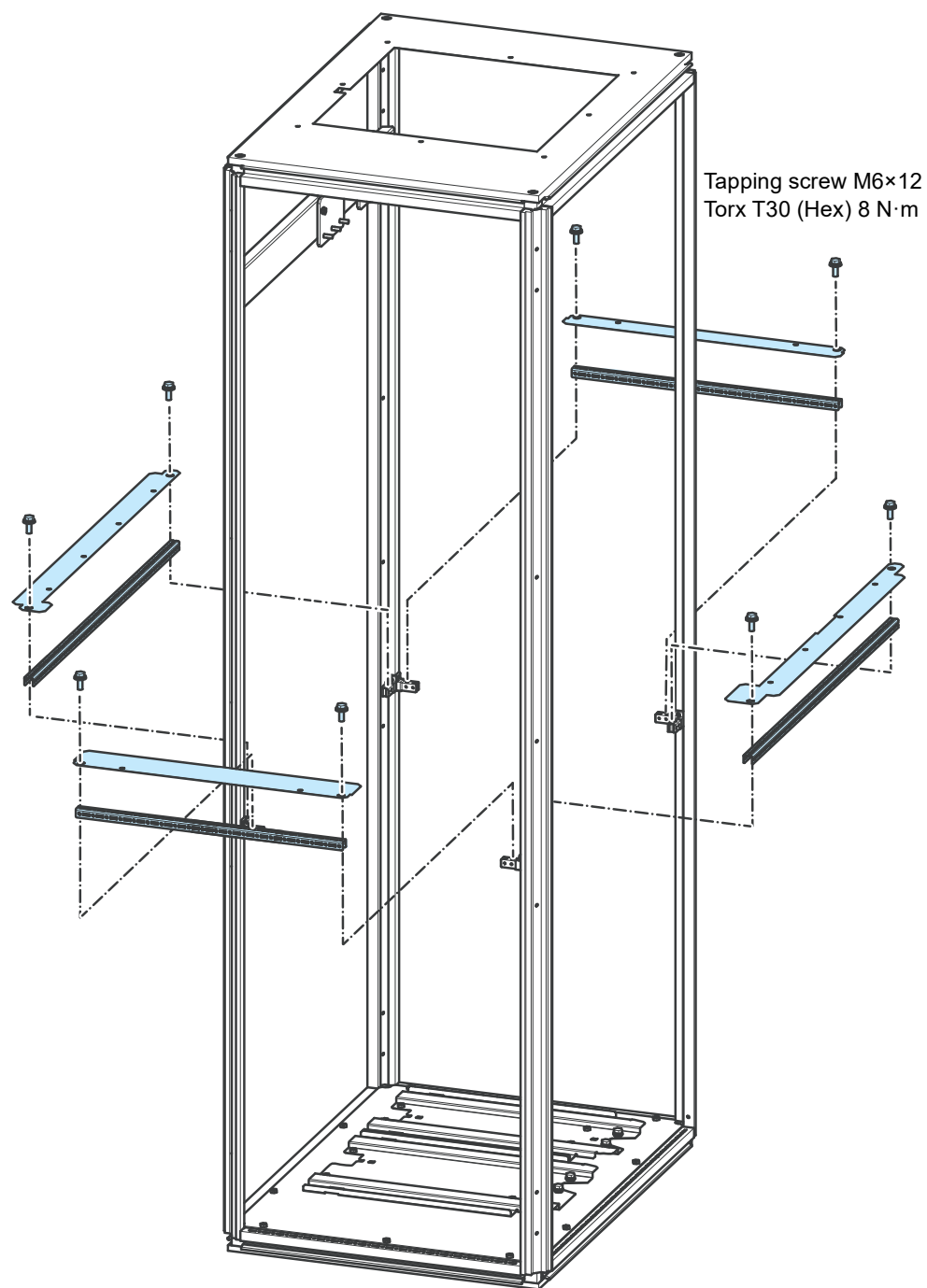

EU Declaration of Conformity

Machinery Directive 2006/42/EC

We

Manufacturer: ABB Oy
Address: Hiomotie 13, 00380 Helsinki, Finland.
Phone: +358 10 22 11

declare under our sole responsibility that the following products:

Frequency converters

ACS880-01/-11/-31

ACS880-04/-04F/-M04/-14/-34

with regard to the built-in safety function:

Safe torque off;

and with regard to the following optional safety functions with FSO-12 module (option code +Q973, encoderless):

Safe stop 1; Safe stop emergency; Safely-limited speed; Safe maximum speed; Safe brake control; Prevention of Unexpected Start-up;

and with regard to the following optional safety functions with FSO-21 and FSE-31 modules (option codes +Q972 and +L521):

Safe stop 1; Safe stop emergency; Safely-limited speed; Safe maximum speed; Safe brake control; Safe speed monitor; Safe direction; Prevention of Unexpected Start-up;

and with regard to the following optional safety function with FPTC-01 thermistor protection module (option code +L536):

Safe Motor Temperature;

are in conformity with all the relevant safety component requirements of EU Machinery Directive 2006/42/EC, when the listed safety functions are used for safety component functionality.

3AXD1000099646

1 (2)



The following harmonized standards have been applied:

EN 61800-5-2:2007	Adjustable speed electrical power drive systems – Part 5-2: Safety requirements - Functional
EN 62061:2005 + AC:2010 + A1:2013 + A2:2015	Safety of machinery – Functional safety of safety-related electrical, electronic and programmable electronic control systems
EN ISO 13849-1:2015	Safety of machinery – Safety-related parts of control systems. Part 1: General requirements
EN ISO 13849-2:2012	Safety of machinery – Safety-related parts of the control systems. Part 2: Validation
EN 60204-1:2006 + A1:2009 + AC:2010	Safety of machinery – Electrical equipment of machines – Part 1: General requirements

The following other standards have been applied:

IEC 61508:2010	Functional safety of electrical / electronic / programmable electronic safety-related systems
IEC 61800-5-2:2016	Adjustable speed electrical power drive systems – Part 5-2: Safety requirements - Functional

The products referred in this Declaration of conformity fulfill the relevant provisions of other European Union Directives which are notified in Single EU Declaration of conformity 3AXD10000497831.

Person authorized to compile the technical file:

Name and address: Ari Korpela, Hiomotie 13, 00380 Helsinki, Finland.

Helsinki, 29 Jan 2018

Manufacturer representative:

Vesa Kandell
Vice President, ABB Oy

3AXD1000099646

2 (2)

Further information

Product and service inquiries

Address any inquiries about the product to your local ABB representative, quoting the type designation and serial number of the unit in question. A listing of ABB sales, support and service contacts can be found by navigating to www.abb.com/searchchannels.

Product training

For information on ABB product training, navigate to www.abb.com/drives and select *Training courses*.

Providing feedback on ABB Drives manuals

Your comments on our manuals are welcome. Go to www.abb.com/drives and select *Document Library – Manuals feedback form (LV AC drives)*.

Document library on the Internet

You can find manuals and other product documents in PDF format on the Internet. Go to www.abb.com/drives and select *Document Library*. You can browse the library or enter selection criteria, for example a document code, in the search field.

Contact us

www.abb.com/drives

www.abb.com/drivespartners

3AXD50000212446 Rev A (MUL) 2018-03-23